

critical specification data sheet

# The BF750L

## Bag Filter Unit

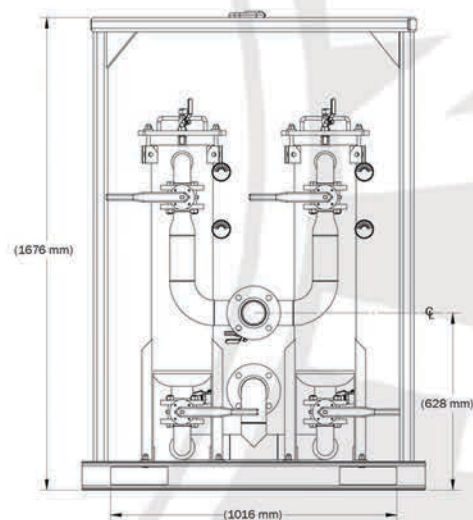
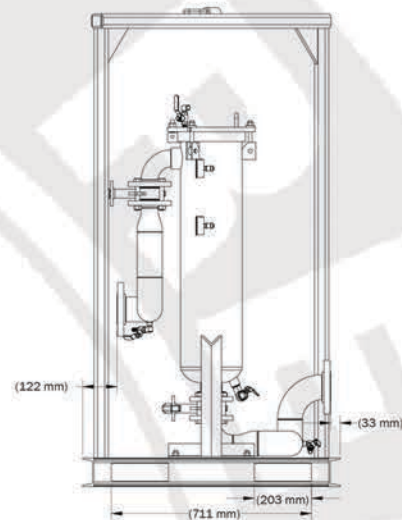
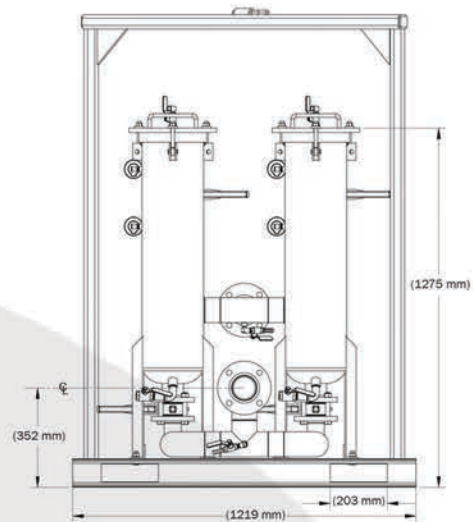

### Overview:

The BF750L bag filter unit features two bag filter tanks and utilises 178 x 762 mm bag filters for superior filtration from 100 to 1 micron for flows up to 750 L/min.

### Features and Benefits:

- No moving parts
- Skid mounted
- Fitted with bleed valves and pressure gauges
- Chambers constructed of 304 stainless steel
- Piping constructed of 304 stainless steel
- Stainless steel inlet and outlet manifolds
- ASME and CE certified
- Manufactured in a ISO9001 certified manufacturing facility

### Specification:

|                |                   |
|----------------|-------------------|
| Max Flow       | 750 L/min         |
| Material       | stainless steel   |
| Max Pressure   | 125 psi / 8.6 bar |
| Dry Weight     | 364 kg            |
| Footprint      | 1219mm x 914mm    |
| Inlet / outlet | 3" x 3" flange    |

### Accessories:

- Spillguard
- Suction and discharge hoses



0845 900 2841  
rainforrent.co.uk

# Liquid Ingenuity®